

# TRÜTZSCHLER

NONWOVENS

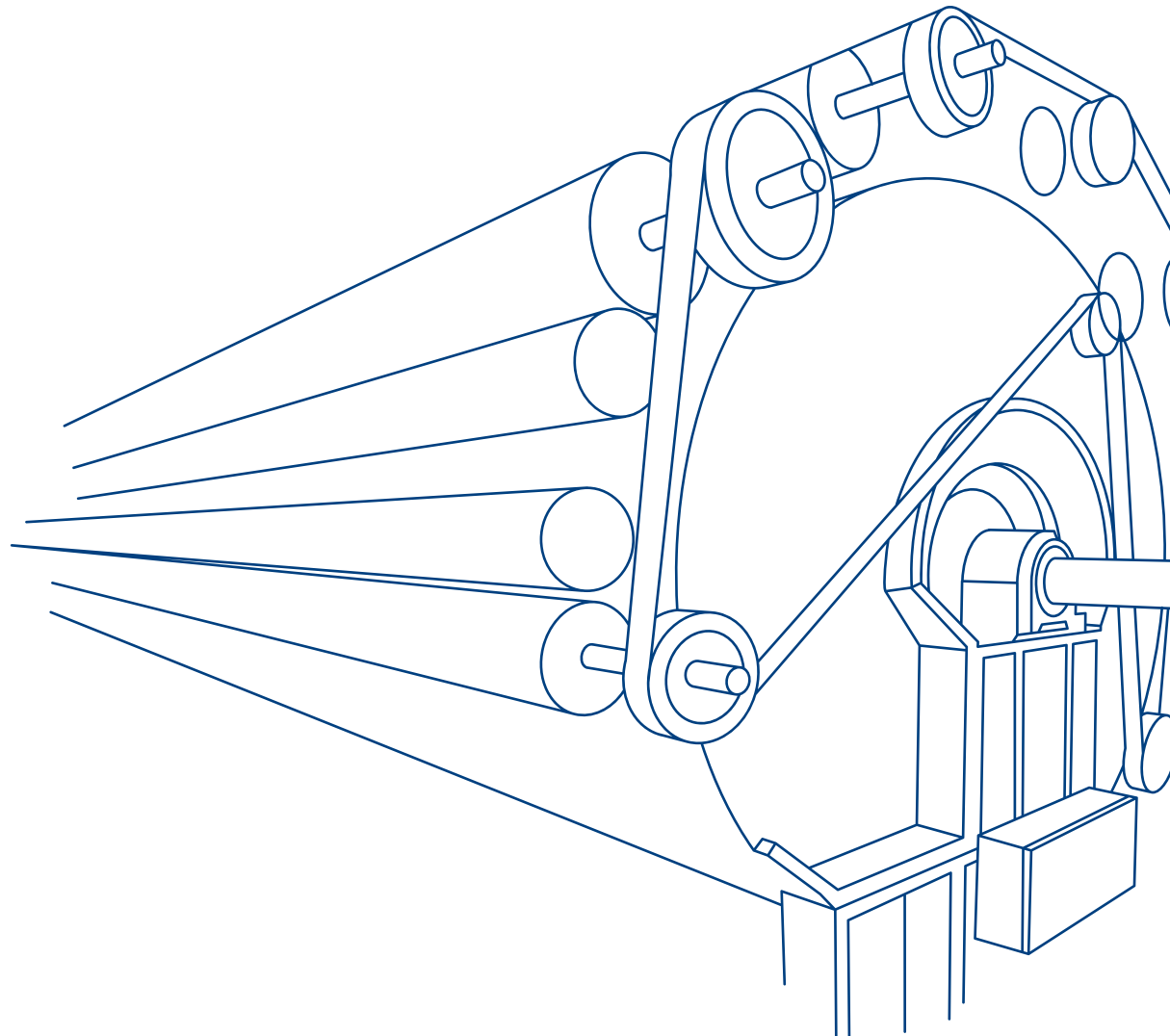



true family	06
true innovation	08
Complete nonwoven lines	12
The Team: AquaJet / Dryer	14
Roller card technologies	16
Customer- and Technology Center	18
Wipes made of cotton	20
WLS wipes	22
Hygiene nonwovens	24

it's true  
it's truetzschler

## Focussed on your success

At Truetzschler, true customer orientation means: We use our expertise, our in part decade-old contacts and our market-leading technologies to help you achieve your personal goals. These can be best quality, maximum economy or first-class efficiency.

Either way, we keep our promise to do everything in our power to give you a competitive edge in your market and to permanently expand it.



# true family

Others focus on quarterly figures.  
We keep an eye on your success.

Fortunately, worrying about satisfied investors is not one of our priorities. Truetzschler is a family-owned company that focuses on people, some of whom we have been working with for generations. We listen to you very carefully and know which individual goals you are pursuing with your natural and man-made fiber processing.



You

To us, family business means to shape the future together – with you. This is precisely what we focus on to ensure your long-term success.

> 130

Spunlacing  
Lines

3,000

Employees  
worldwide

13

Locations  
worldwide

# true innovation

Because we are heading in the right direction,  
you have continuous tailwinds.

For many, technological progress is the further development of an existing solution or a revolutionary design. Truetzschler's aspiration is to open up new competitive advantages for you. We achieve this time and again by being the first to cross technological horizons.

The resulting solutions help you to produce your quality yarns and non-wovens products more efficiently and of higher quality – and that is what counts.

## 1929

Inventor of the through-air principle for drying wet/dyed textiles. Our patent for the perforated drum becomes the efficiency standard for dryer technologies.

## 1996

AquaJet – the first hydroentanglement with up to 400 bar water pressure makes applications for filter fabrics as well as solid and heavy technical textiles possible. The most important field of application are consumer goods such as wipes, etc.

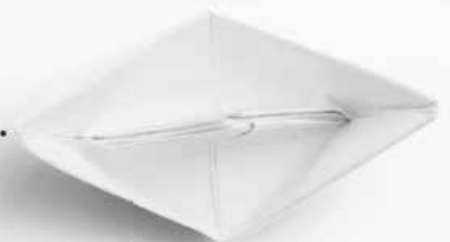



# 2012

Acquisition of Bastian in the winder area.  
Complete lines from web formation to the  
wound product are perfectly coordinated.

# 2006 2009

Truetzschler expands its portfolio through  
the acquisitions of Erko in Dülmen and  
Fleissner in Egelsbach. Lines for non-  
wovens range from web formation to  
web bonding and finishing.

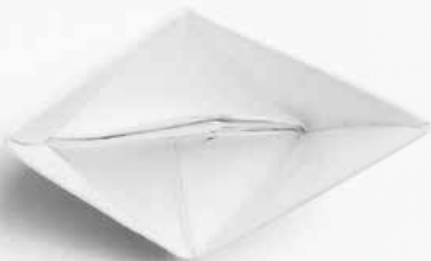

**TRÜTZSCHLER**  
NONWOVENS

# The true way to quality nonwovens

Our passion is machines and everything associated with the economic production of high-quality nonwovens. We love the challenge of opening up new fields of application with new materials and innovative technologies.

For you – our customers – we have our finger on the pulse of the markets and turn trends into solutions. We always want to provide you with new opportunities to manufacture successful products. In concrete terms this means: we do not wait until you make a new demand on us, but we proactively develop concepts from which you will profit in the future.

An example? Our complete nonwoven production lines in cooperation with Voith for the production of “green” wet-laid and spunlaced nonwovens based on cellulose.

We do not know what the future holds, but the best way to predict the future is to shape it yourself. If you are always searching for new ways, join us on the true way to successful products.

# On the road to success with complete nonwoven lines

When you choose machines and installations from Truetzschler Nonwovens, you can be sure that everything comes from a single source. All process steps – from fiber opening to final slitting and winding – are perfectly coordinated.

We accompany you from planning to commissioning, from fiber opening to the finished nonwoven roll. Are you only interested in individual components from our product range? Welcome – our machines also set standards as solitaires.

## THE NONWOVENS PROCESS CHAIN

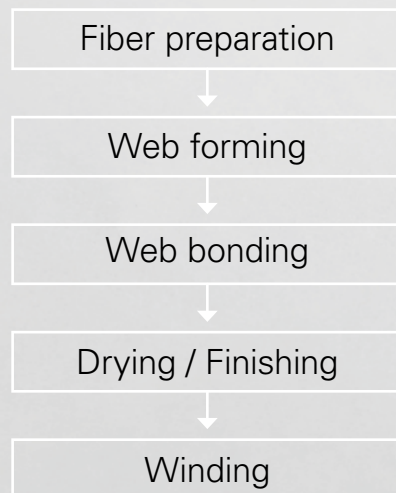



## **FORGE AHEAD**

Whatever fiber you want to use – machines and installations from Truetzschler Nonwovens enable an optimal production process.

# An unbeatable team: AquaJet and drum dryer

It has been convincing from 1996 to this day: our AquaJet is used in far more than 130 installations for the production of hydroentangled nonwovens. Its range of applications extends from lightweight nonwovens for wipes and medical textiles to coating substrates, geotextiles and filtration media.

The key components of the AquaJet – jet head and spunlace drum – score with intelligent, still unsurpassed design. Together with the high flexibility achieved with 3 compacting systems and 4 different suction systems, they form the basis for the market success.

## **ENERGY EFFICIENT DRYING**

To dry the wet nonwoven without loss of quality, we rely on our many years of experience. In 1929 we developed the first drum dryer based on the through-air principle. To this day, we are constantly optimizing the energy-intensive drying process. The energy efficiency of our latest generation of multi drum dryers has once again increased significantly.



## **OUTSTANDING PERFORMANCE**

An AquaJet in combination with one of our drum dryers brings the quote *"The whole is greater than the sum of its parts"* to life. The duo is optimally balanced, high-performing and efficient.

# Many ways to the perfect web: our roller card technologies

The focus is on your end product, its properties and the fiber material which determine the optimum machines for web formation. Single or multi-layer webs, parallel or random web, natural, man-made or other fibers – we have a solution for all requirements.

If your goal is the perfect balance between quality, productivity and profitability, you have come to the right place. With our 4 different types of roller cards and a variety of possible configurations we will find the optimal web formation for you. We not only promise this on paper, but also prove it in reality – time and again.

## 4

### TYPES OF ROLLER CARDS

- Universal roller card NC for various bonding methods
- High-speed card NCT – for high-performance lines with 300 m/min at the winder and more...
- Random card NCR – for natural fibers of different lengths
- Airlay card NCA – for processing of short fibers

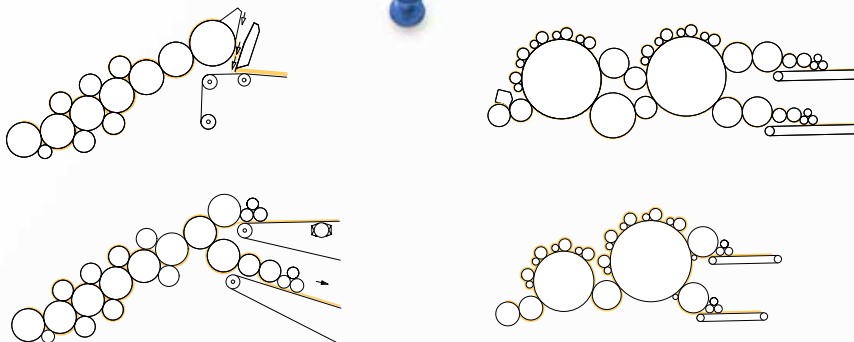



**THE PERFECT BALANCE** | We implement your requirements in a way that ensures optimal production of your desired product.



# Our Technology Center? Your Customer Center!

In our Nonwovens Customer and Technology Center (NCTC) in Egelsbach your ideas become reality: here you can design your desired product and put our machines through their paces. A team of experienced experts develops the optimum manufacturing process with you.



The 2 lines installed offer a maximum of decision-making reliability. Make your investment decision with the certainty that the chosen solution delivers in practice what it promises on paper. Use our lines and our know-how to test your own raw materials or to check the feasibility of a new product idea. In any case, our focus is on you and your requirements.



### **EASILY ACCESSIBLE**

The NCTC – Nonwovens Customer & Technology Center – of Truetzschler Nonwovens is located in Egelsbach. Only 15 kilometres away from the Frankfurt/Main Airport it is easily accessible, both nationally and internationally.



# Sustainability and convenience?

## Yes, please.

Whether cosmetic or refreshing wipes, disinfection or baby care: ultra-fine nonwovens made of cotton give a growing target group a feeling of luxury. With our special web formers, the random card and the airlay card, you can produce premium products that not only set haptic standards. These nonwovens biodegrade and thus outperform conventional wet wipes made of polyester/viscose blends, also with regard to their environmental compatibility.

### **GREEN WIPES**

Spunlace wipes from Truetzschler Nonwovens process more than just bleached virgin cotton fibers without problems. Unbleached fibers, fiber blends and even inexpensive comber noils can be processed into marketable products.

## With black numbers in a green future

Conventional wet wipes are good because they are practical and hygienic. However, they usually consist of blends of viscose and polyester or polypropylene fibers. These man-made fibers do not decompose – they will still be traceable as microplastics one hundred years from now.

Pulp, the starting material used in paper production, and regenerated cellulose fibers, on the other hand, are a renewable raw material and completely biodegradable. Our reliable wet-laid/spunlace technology (WLS) is designed precisely for this material. In cooperation with Voith, leading partner and pioneer in the paper industry, we offer complete installations for wet-laid and spunlaced webs. This way ecology and economic success can go hand in hand.

## **NEXTLEVEL WIPES: PRODUCTS FOR TOMORROW**

Wet wipes made of pulp and regenerated cellulose fibers provide the same performance as conventional products. These wet-laid and hydroentangled nonwovens are strong, soft, practical, economical – and biodegradable. A product in cooperation with Voith.

**VOITH**



# Sometimes strong changes are completely gentle

Due to rising incomes and social changes worldwide, the market for disposable hygiene products is becoming ever larger. The growing demand for diapers and incontinence products encourages manufacturers of consumer goods and mechanical engineers alike.

With technology from Truetzschler Nonwovens you are optimally prepared for this trend. Because it is part of our philosophy to think ahead and to develop new processes for our machines again and again. Thus, you too can respond early to changes and ride the wave.



## **SUPER-SOFT HYGIENE NONWOVENS**

Whether baby diapers or incontinence pads - with our roller cards and thermobonders you can produce the thinnest thermobonded nonwovens from bicomponent fibers. They are so soft and flexible that no skin irritations occur.



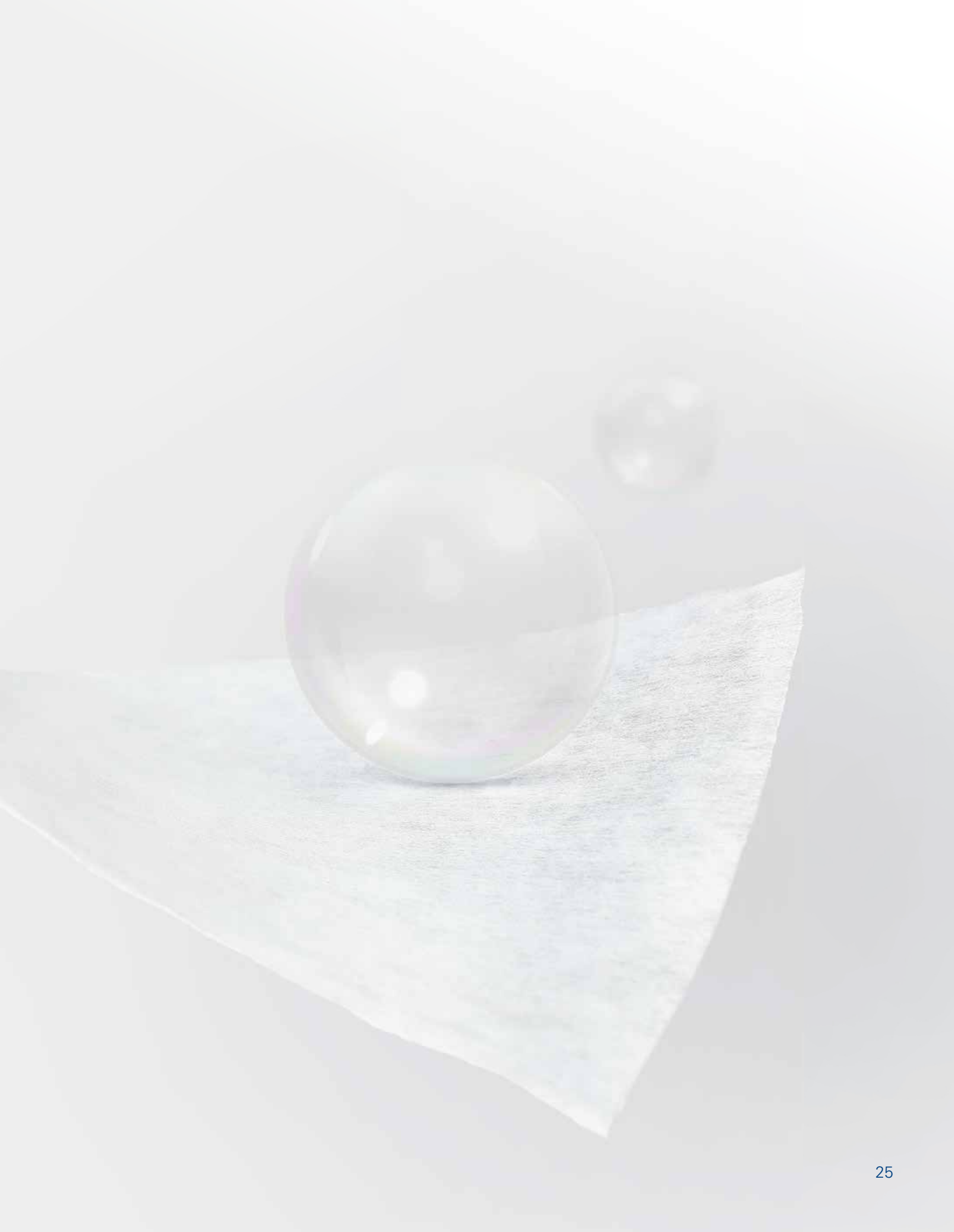



**GERMAN**   
**Technology**



[www.machines-for-textiles.com/blue-competence](http://www.machines-for-textiles.com/blue-competence)

**Trützschler Nonwovens & Man-Made Fibers GmbH**  
Wolfgangstraße 6 · 63329 Egelsbach, Germany  
Telephone: +49 (0)6103 401-0 · Fax: +49 (0)6103 401-440  
E-mail: [nonwovens@truetzschler.de](mailto:nonwovens@truetzschler.de)

**Trützschler Nonwovens GmbH**  
Halterner Straße 70 · 48249 Dülmen, Germany  
Telephone: +49 (0)2594 5099-0 · Fax: +49 (0)2594 5099-100  
E-mail: [nonwovens@truetzschler.de](mailto:nonwovens@truetzschler.de)



**Legal disclaimer:**

The brochure has been compiled to the best of our knowledge and in good faith with the utmost care. However, it may be subject to type errors or technical changes for which we assume no liability. The photos and illustrations are purely informative in nature and in part show special equipment options which do not feature in the standard scope of delivery. We provide no guarantee as to the current nature, correctness, completeness or quality of the information provided. Warranty claims for material or immaterial damage against us or the respective author based on the use or forwarding of the information provided, even if the information is incorrect or incomplete, cannot be asserted. Our provided data is non-binding.

**TRÜTZSCHLER**  
S P I N N I N G

Fiber preparation installations: Bale openers · Mixers · Cleaners /  
Openers · Foreign part separators · Dust separators · Tuft blenders  
Waste cleaners | Cards | Draw frames | Combing machines | Digital  
Solutions: My Mill · My Production App · My Wires App

**TRÜTZSCHLER**  
N O N W O V E N S

Bale openers/Mixers | Card feeders | Cards/Crosslappers  
Wet laying lines | Hydroentangling, needling, thermo- and chemical  
bonding lines | Finishing, drying, winding, slitting machinery

**TRÜTZSCHLER**  
M A N - M A D E F I B E R S

Filament lines: Carpet yarns (BCF) · Industrial yarns

**TRÜTZSCHLER**  
C A R D C L O T H I N G

Metallic wires: Cards · Cards long staple · Cards Nonwovens  
Rotor spinning | Flat tops | Fillets | Carding segments  
Service machines | My Wires App | Service 24/7

it's true  
it's truetzschler

[www.truetzschler.com](http://www.truetzschler.com)